

Product Assembly : Double Wardrobe

FTO - WD02PLR / V3P

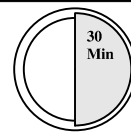

This assembly requires two people.

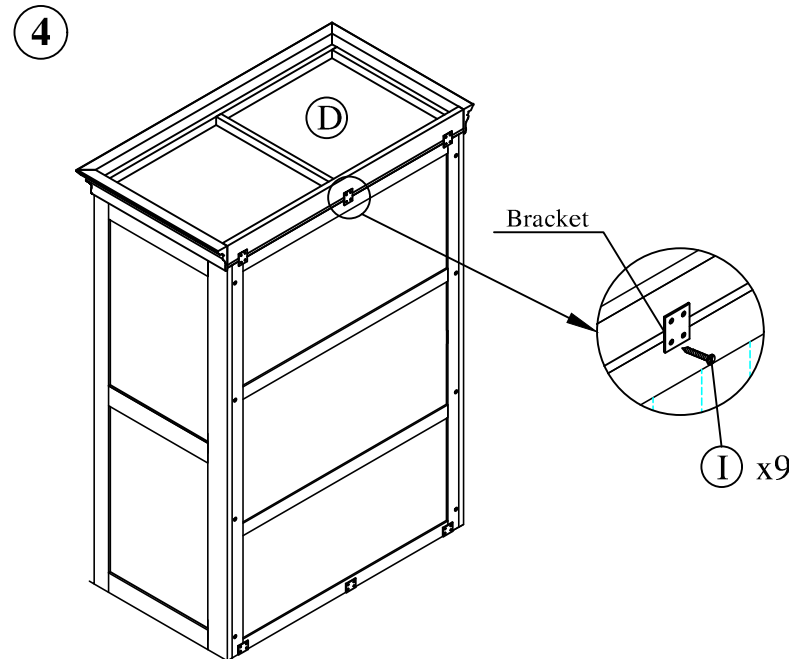
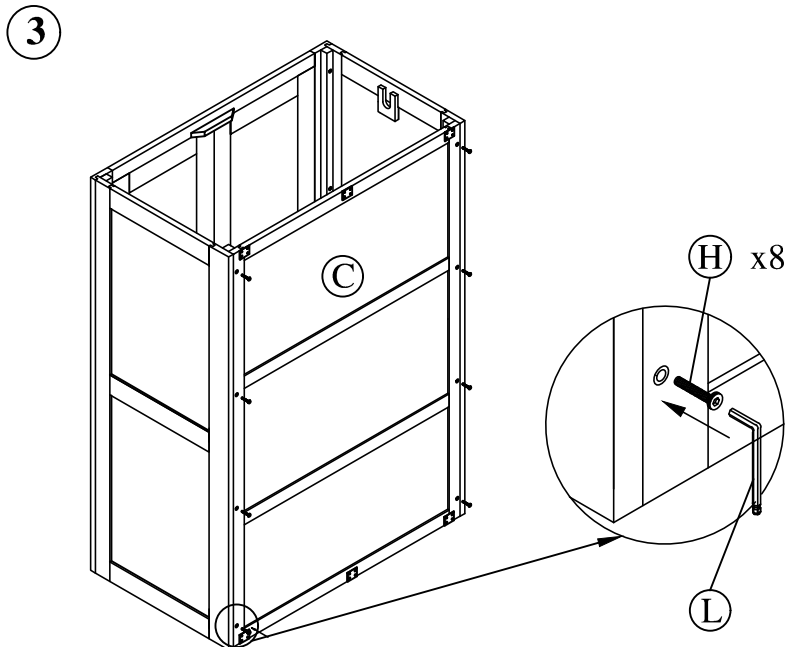
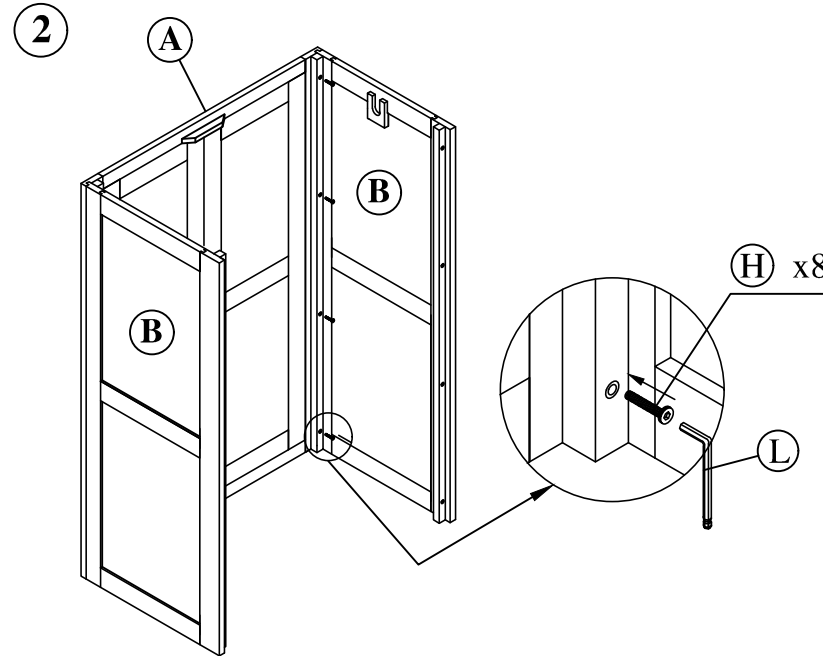
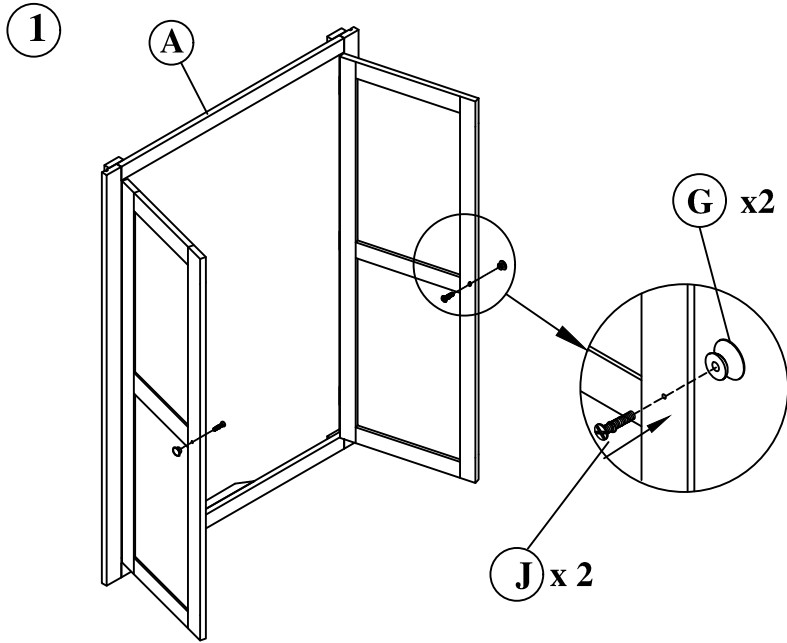

A : Door Frame x 01



B : Side Frame x 02

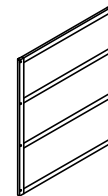

C : Back Frame x 01

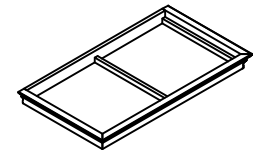

D : Top Frame x 01

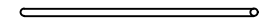

E : Hanging Rail x 01

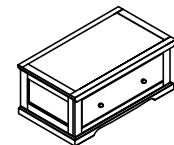

F : The base x 01

Product Assembly : Double Wardrobe
FTO - WD02PLR / V3P

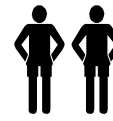
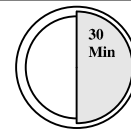

This assembly requires two people.

5

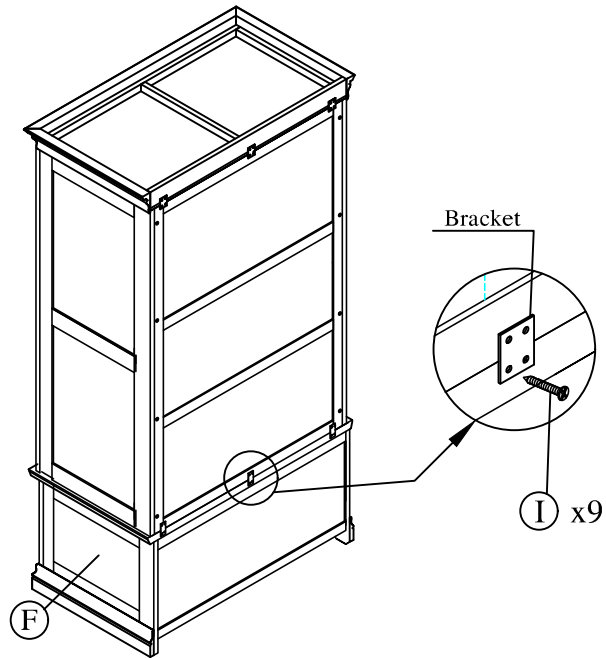

6

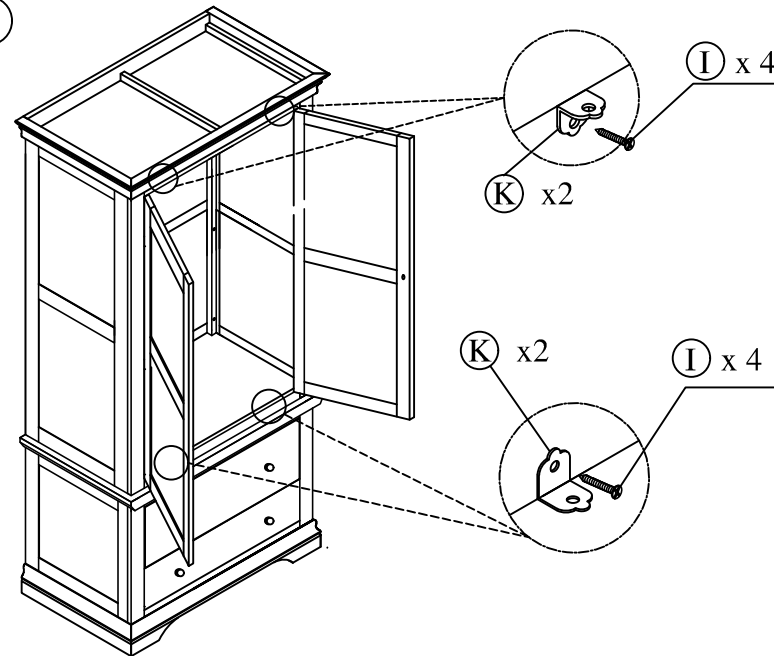

7

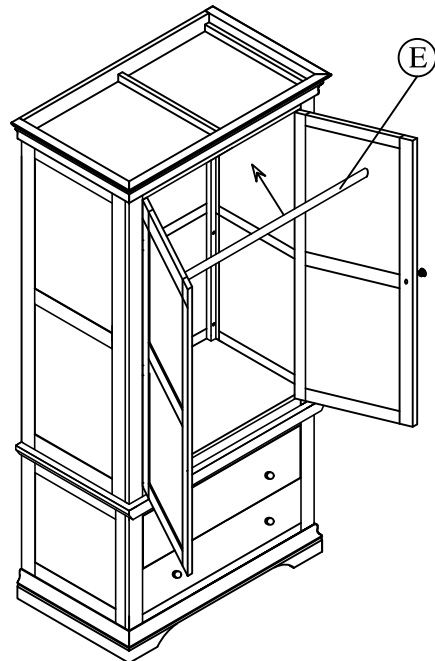

8

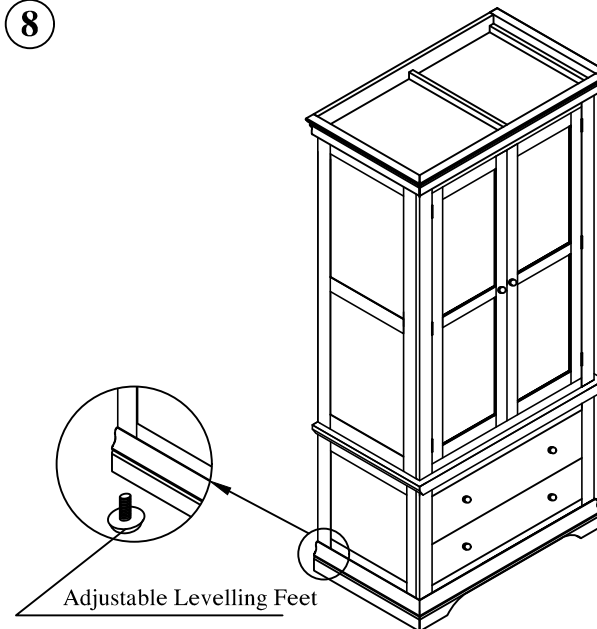

G : Handle x 02

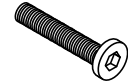

H : Bolt 30 mm x 16

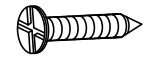

I : Screws 15mm x 26



J : Screws 30 mm & washer x 02



K : Metal Corner x 04

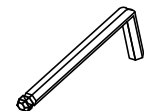

L : Allen Keys x 02