

# ASSEMBLY INSTRUCTION

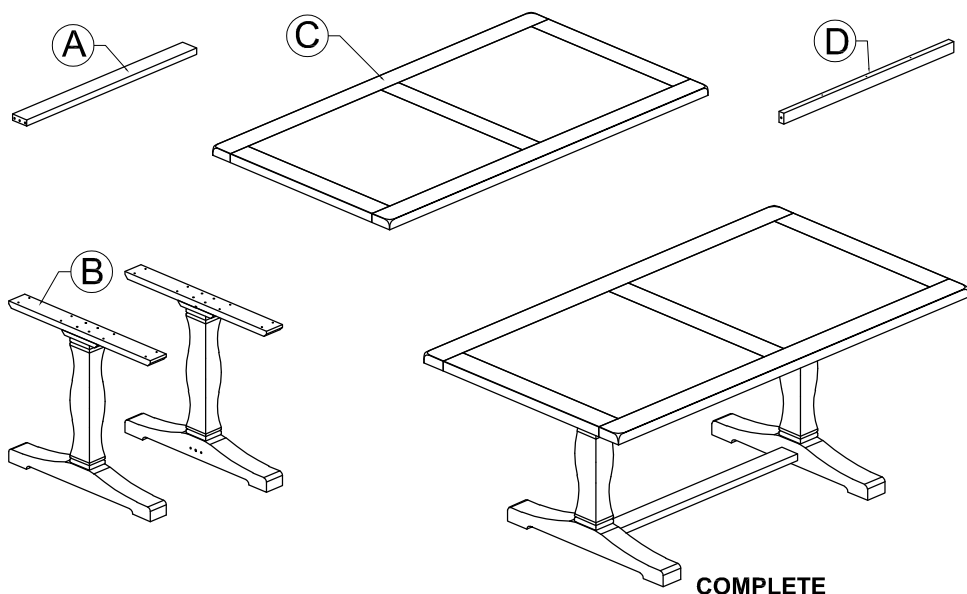







## 2.2M REFECTORY DINING TABLE

### PART LIST

No	Description	QTY	No	Description	QTY
<b>A</b>	LEG CONECTOR	1	<b>C</b>	TABLE TOP	1
<b>B</b>	LEG	2	<b>D</b>	TOP CONECTOR	1

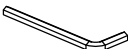

### HARDWARE LIST

No	Description	QTY	No	Description	QTY
<b>1</b>	Dowel - Ø10x30 	4	<b>5</b>	Bolt M8x50 	4
<b>2</b>	Bolt M6x40 	16	<b>6</b>	Lock Washer M8 	4
<b>3</b>	Flat Washer M6/M14 	16	<b>7</b>	Half Moon Washer M8 	4
<b>4</b>	Allen Key - 4 	1	<b>8</b>	Screw M4x40 	3

**1**

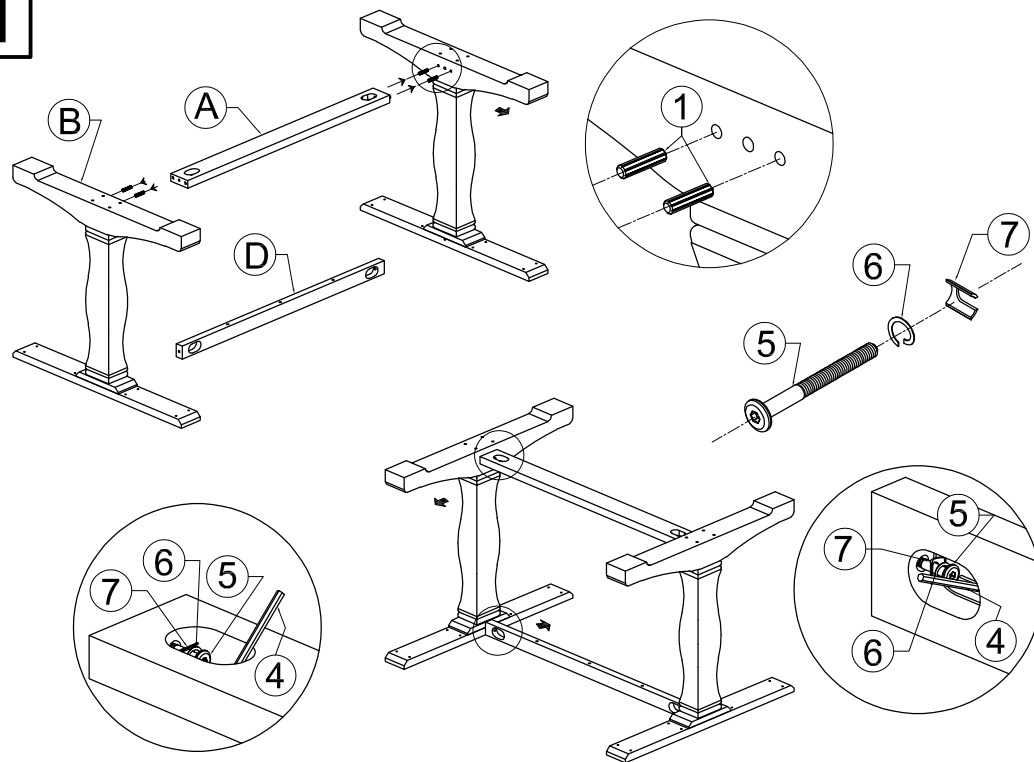

**2**

